



# Top-tier office space available in Cleveland's historic Warehouse District

west 6th street

Johnny's  
DOWNTOWN

**TAZA**  
A LEGANER GROUP

JOHNNY'S  
LITTLE BAR

Kvale Antonelli & Raj  
Collaborative Legal Solutions

juvly  
AESTHETICS

**axs**



west 6th street  
CLEVELAND, OH

 **VISCONSI**  
COMPANIES LTD  
building your future on our history



### PROPERTY HIGHLIGHTS

- » Top-tier office space available in Cleveland's Historic Warehouse District
- » Within walking distance to fine dining, local retail, newly-renovated Public Square and a vibrant nightlife
- » Join ground floor signature restaurants – historic Johnny's Restaurant and Taza

### MAJOR TENANTS

- » Johnny's Downtown
- » Johnny's Little Bar
- » Kvale Antonelli & Raj
- » Taza
- » AXS
- » Juvly Aesthetics

### DEMOGRAPHICS

	1 MI. RADIUS	3 MI. RADIUS	5 MI. RADIUS
Population	13,411	82,886	249,565
Households	6,723	35,526	110,604
Average Income	\$80,327	\$51,883	\$47,321



# In the heart of the work-live-entertainment corridor



CARNEGIE AVE



JACK CLEVELAND CASINO



New Global HQ 2025 OCCUPANCY

PUBLIC SQUARE

west 6th street

Johnny's DOWNTOWN    Taza A LEBANESE GRILL

JOHNNY'S LITTLE BAR    Kvale Antonelli & Raj Collaborative Legal Solutions

juvly AESTHETICS    axs

Huntington Convention Center of Cleveland



ENROLLMENT: 17,260

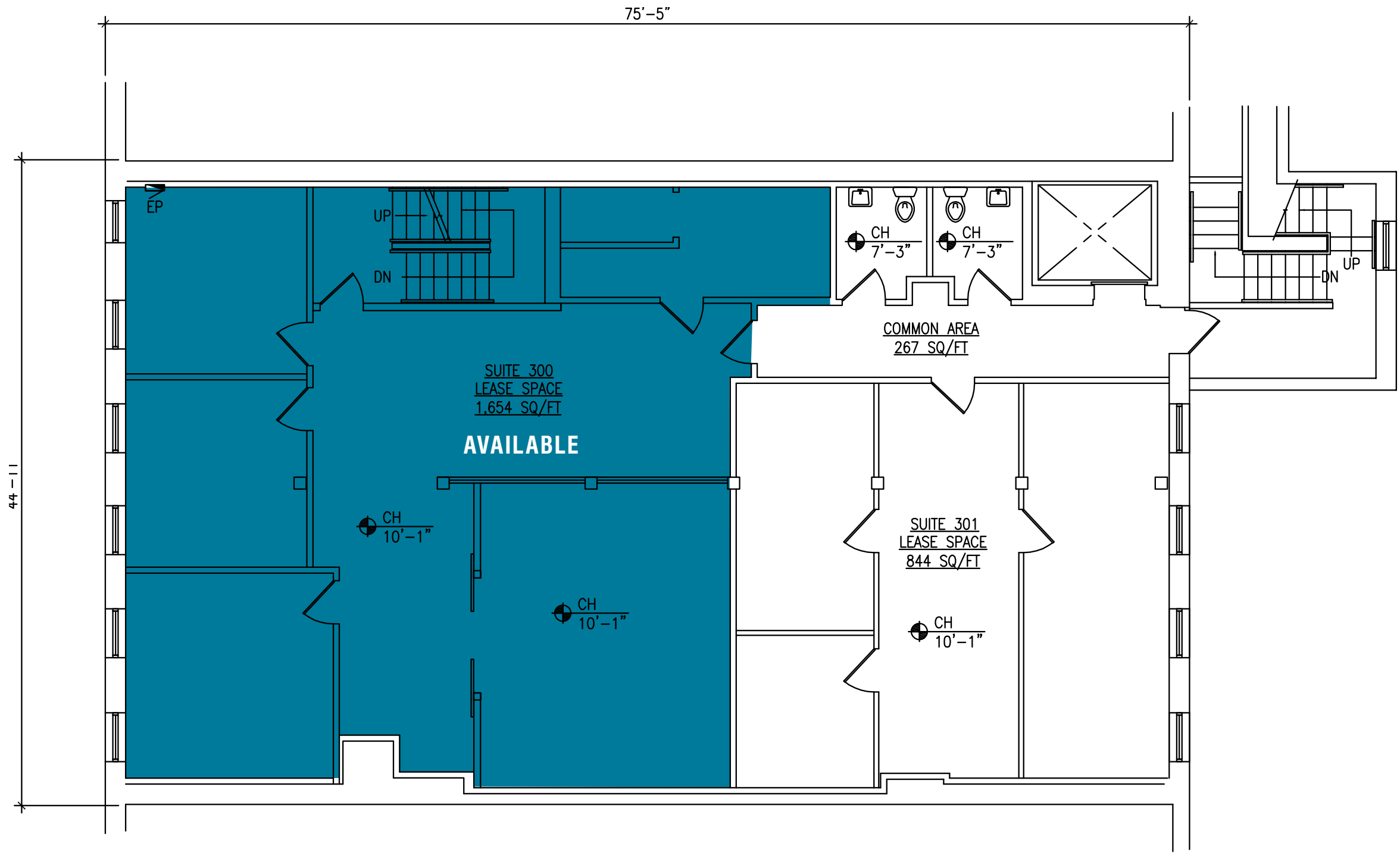

**THIRD FLOOR PLAN - 1400 W. 6TH**

RENTABLE AREA: 3,387 SQ. FT.

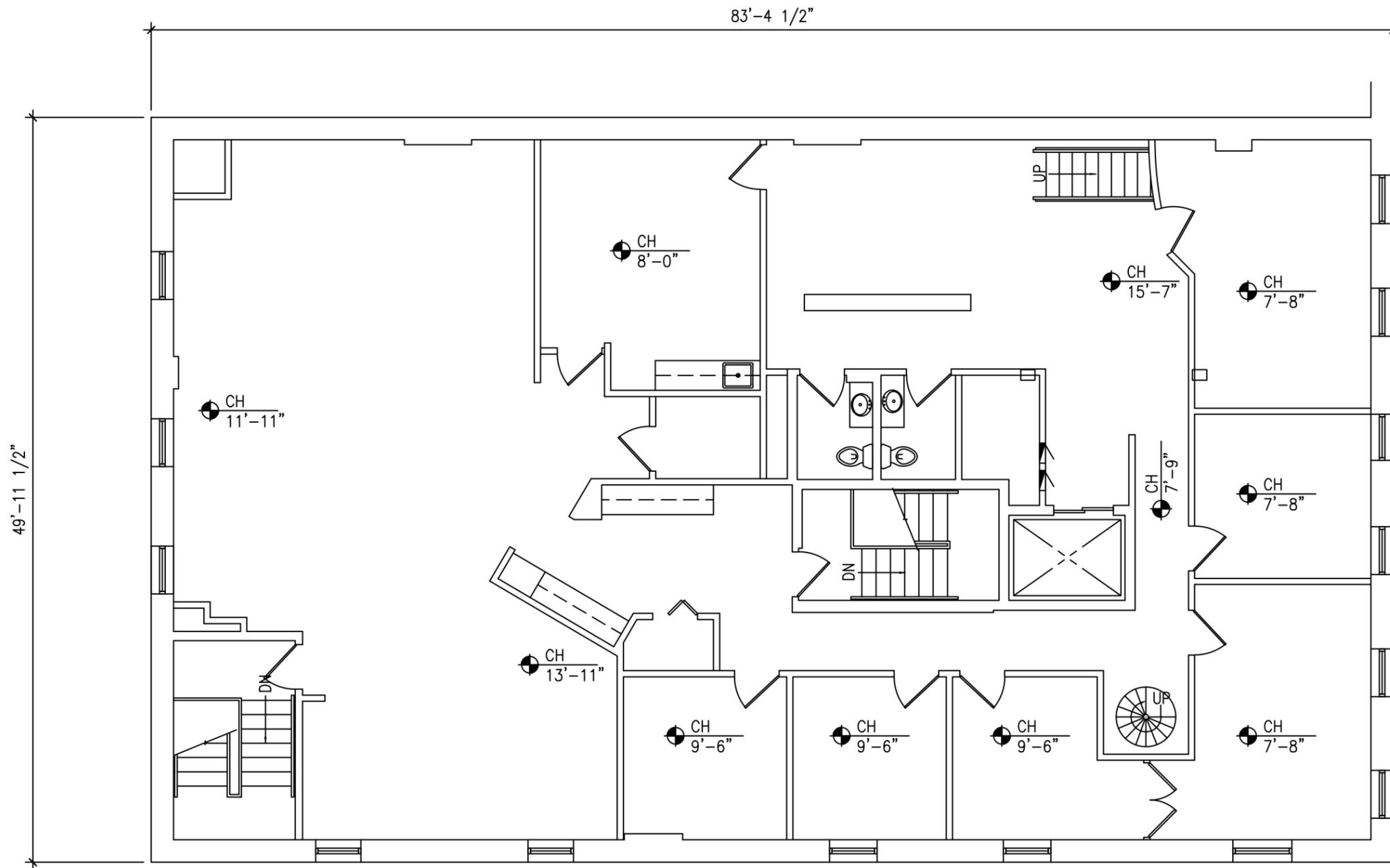

**FOURTH FLOOR PLAN - 1406 W. 6TH**

RENTABLE AREA = 4,997 SQ. FT. (INC. MEZZANINE)

RENTABLE AREA = 4,164 SQ. FT. (EXCL. MEZZANINE)

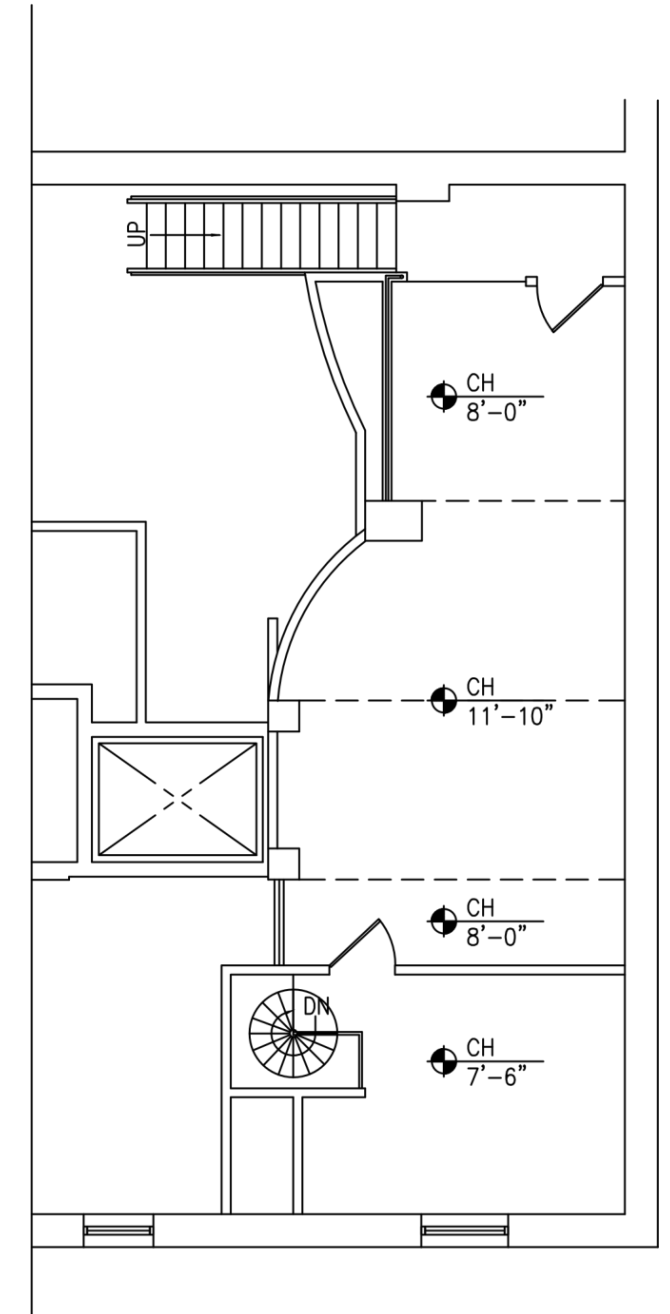

**FOURTH FLOOR MEZZANINE PLAN**

833 SQ. FT.