



Top-tier office space available in Cleveland's historic Warehouse District

west 6th street

Johnny's
DOWNTOWN

TAZA
A LEGANESE GRILL

JOHNNY'S
LITTLE BAR

Kvale Antonelli & Raj
Collaborative Legal Solutions

juvly
AESTHETICS

axs



west 6th street

CLEVELAND, OH



VISCONSI
COMPANIES LTD

building your future on our history



PROPERTY HIGHLIGHTS

- » Top-tier office space available in Cleveland's Historic Warehouse District
- » Within walking distance to fine dining, local retail, newly-renovated Public Square and a vibrant nightlife
- » Join ground floor signature restaurants – historic Johnny's Restaurant and Taza

MAJOR TENANTS

- » Johnny's Downtown
- » Johnny's Little Bar
- » Kvale Antonelli & Raj
- » Taza
- » AXS
- » Juvly Aesthetics

DEMOGRAPHICS

	1 MI. RADIUS	3 MI. RADIUS	5 MI. RADIUS
Population	13,411	82,886	249,565
Households	6,723	35,526	110,604
Average Income	\$80,327	\$51,883	\$47,321



In the heart of the work-live-entertainment corridor



CARNEGIE AVE



JACK CLEVELAND CASINO

RTA

New Global HQ 2025 OCCUPANCY

PUBLIC SQUARE

west 6th street

Johnny's DOWNTOWN **Taza** A LEBANESE GRILL

JOHNNY'S LITTLE BAR Kvale Antonelli & Raj Collaborative Legal Solutions

judly BEAUTY & SKINCARE **axs**



Huntington Convention Center of Cleveland



AMTRAK

ROCK & ROLL HALL OF FAME

ENROLLMENT: 17,260

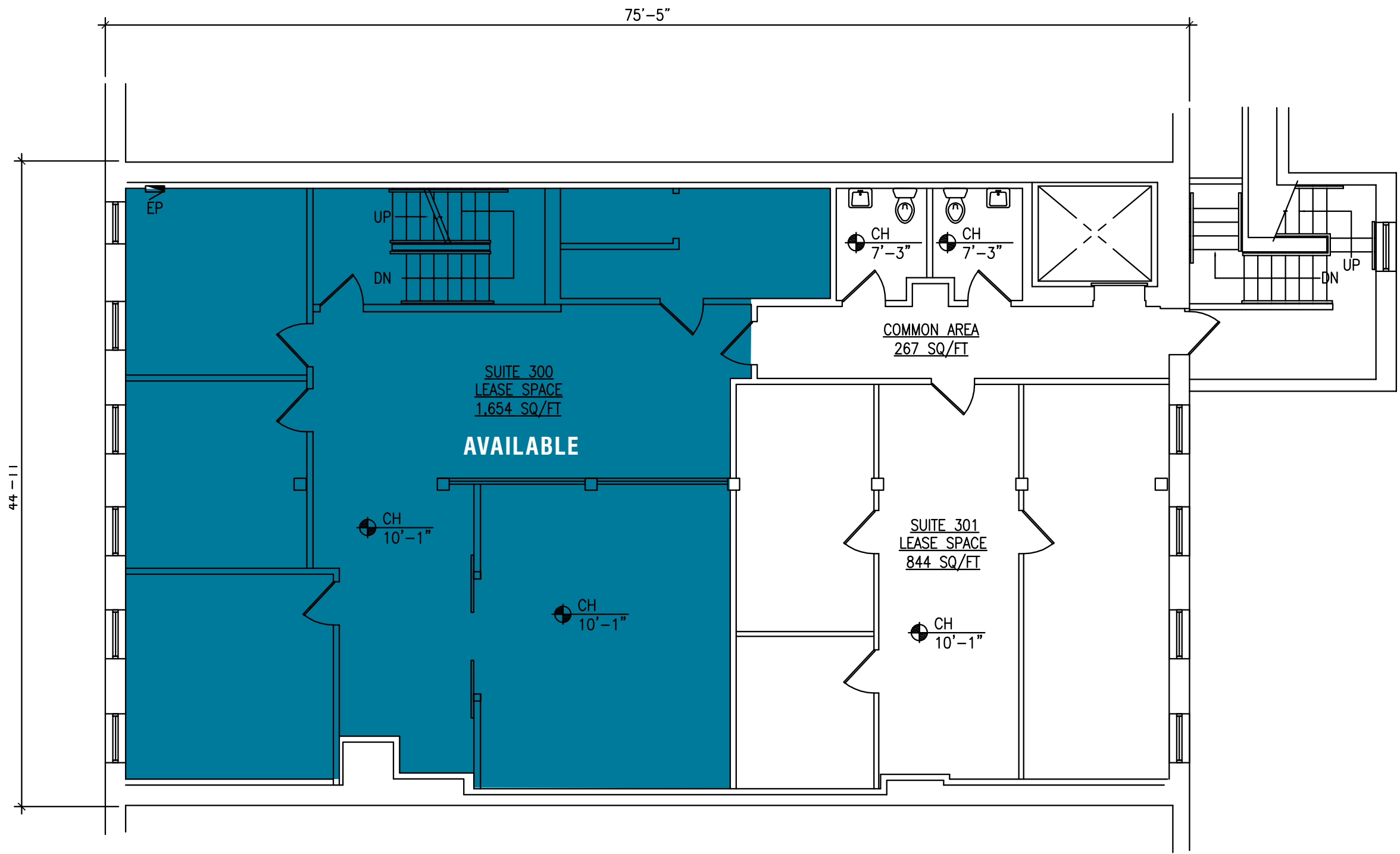

THIRD FLOOR PLAN - 1400 W. 6TH
RENTABLE AREA: 3,387 SQ. FT.

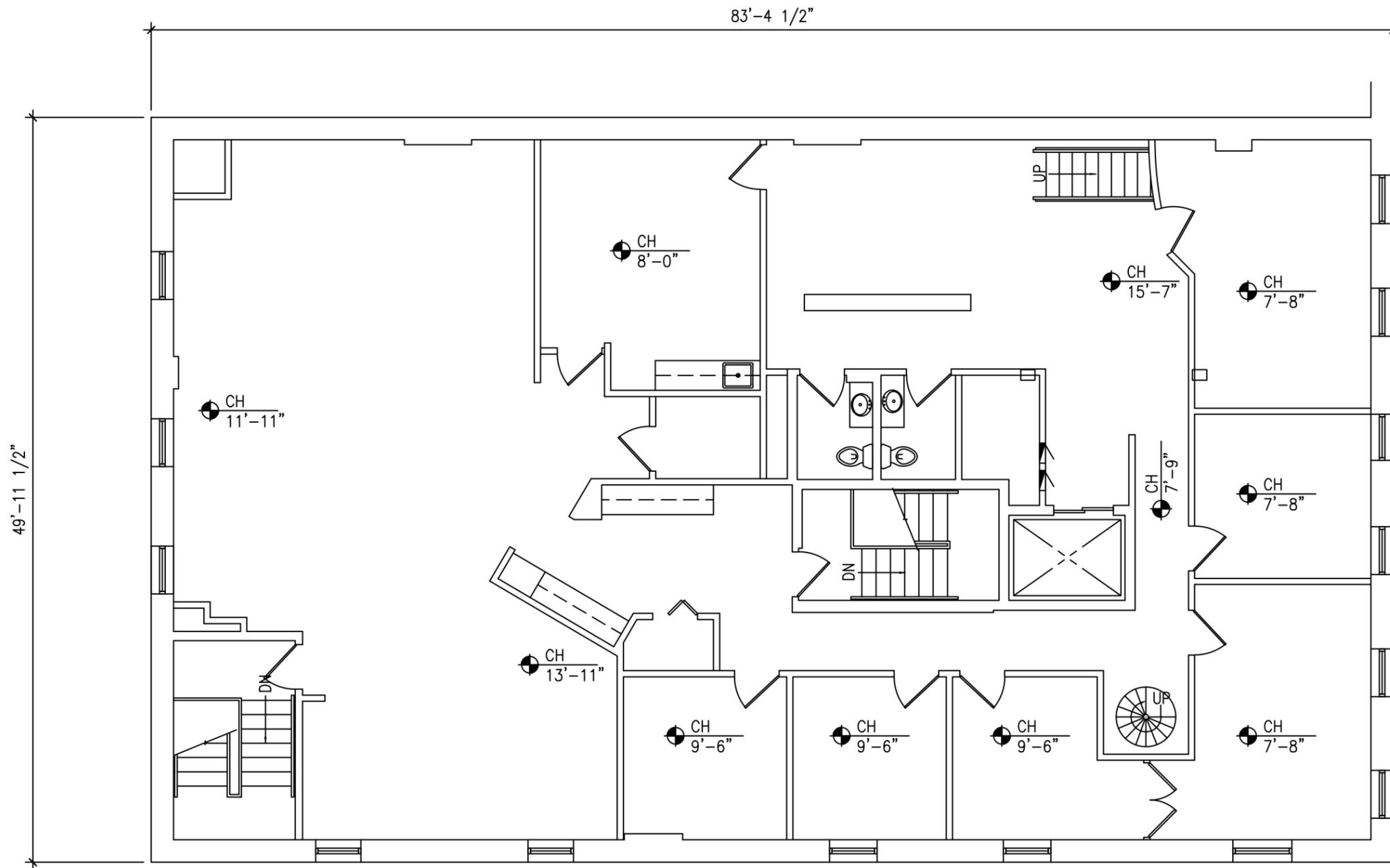

FOURTH FLOOR PLAN - 1406 W. 6TH

RENTABLE AREA = 4,997 SQ. FT. (INC. MEZZANINE)

RENTABLE AREA = 4,164 SQ. FT. (EXCL. MEZZANINE)

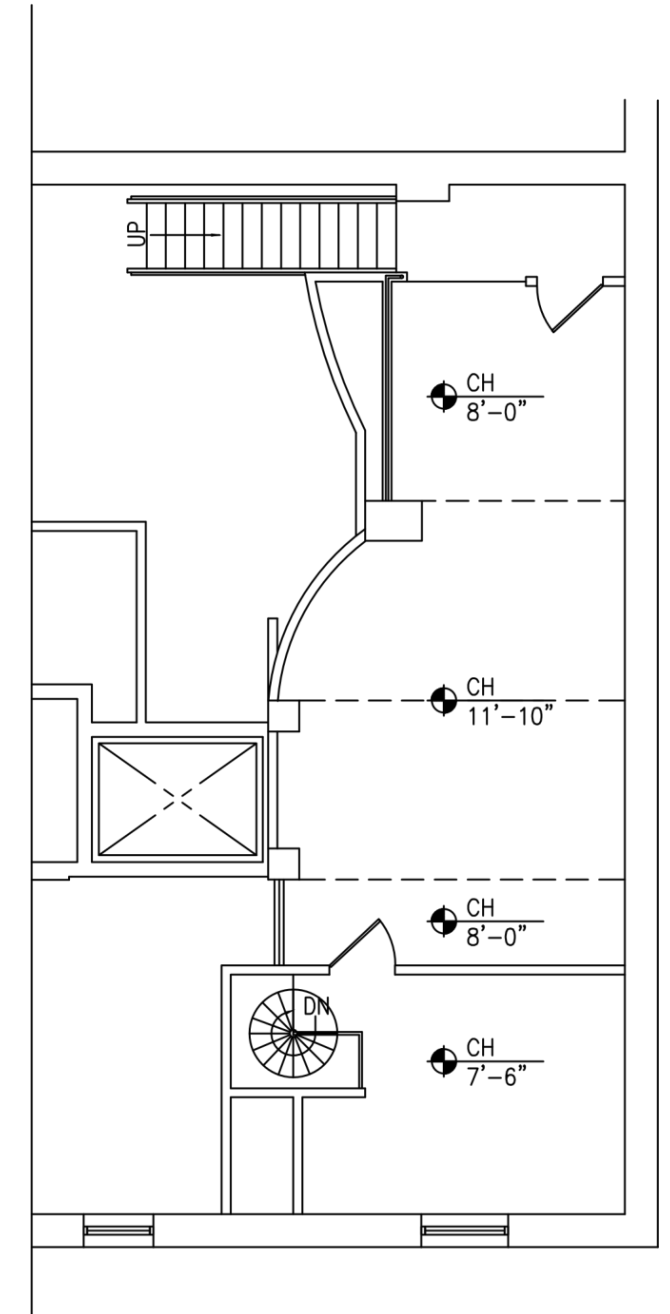

FOURTH FLOOR MEZZANINE PLAN

833 SQ. FT.

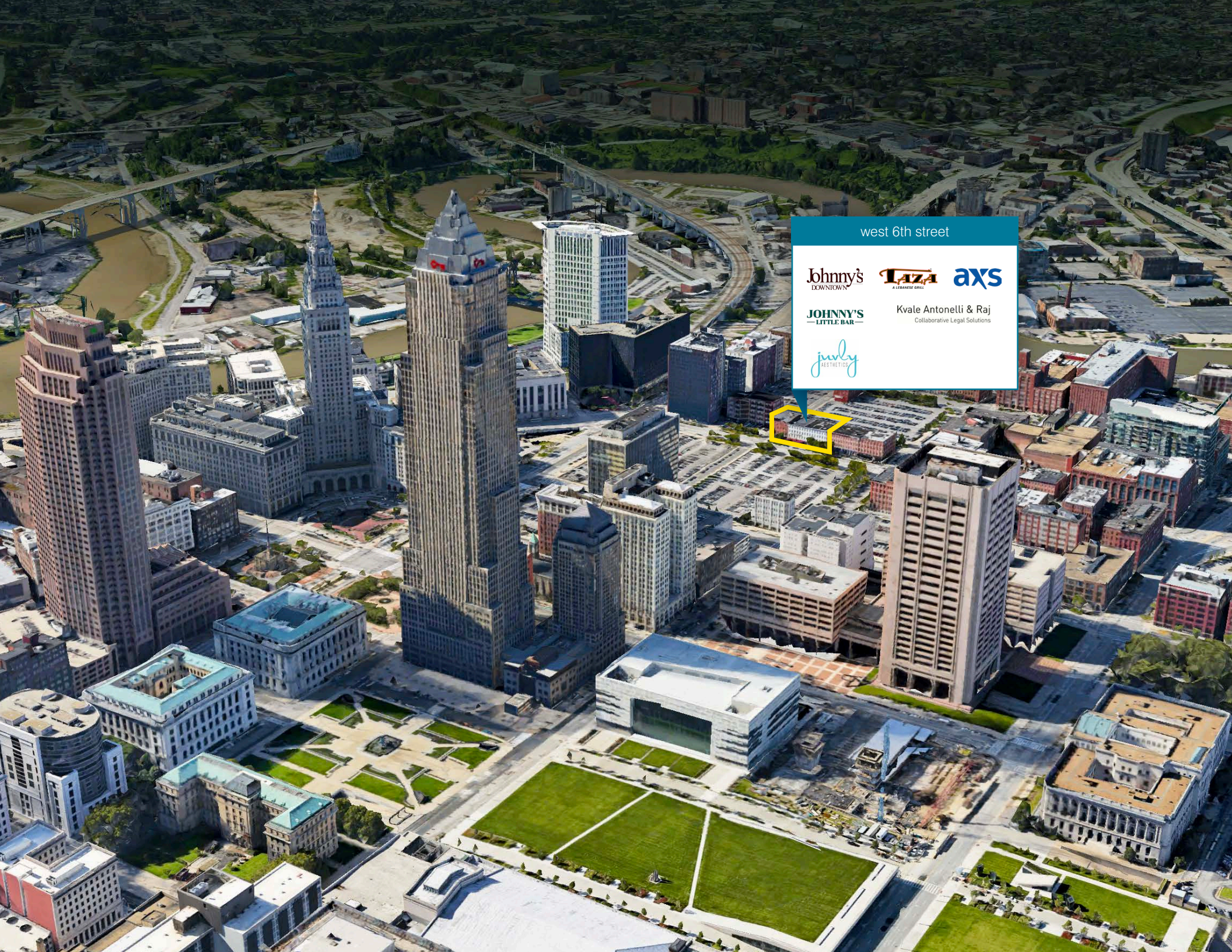

west 6th street

Johnny's
DOWNTOWN

Taza
A LEGANWEE GROUP

axs

JOHNNY'S
LITTLE BAR

Kvale Antonelli & Raj
Collaborative Legal Solutions

juvly
AESTHETICS

